

# 3D-Printed Fabrication of Personalized Ankle Joint For Bio Implants in Medical Applications

Shaik Bazani<sup>1</sup>, E S Bhaskar<sup>2</sup>, Siva Krishna T<sup>3</sup>, Victor Babu P<sup>4</sup>, Siva Kirshna S<sup>5</sup>, A Venkata Mahesh<sup>6</sup>

<sup>1,2,3,4,5</sup> Ramachandra College of Engineering, Eluru, Andhra Pradesh - 534007

<sup>6</sup> Department of Computer Science and Engineering, Miracle Education Society Group of Institutions, Vizianagaram

Received: 2nd Mar, 2026 | Revised: 14th Mar, 2026 | Accepted: 4th Apr, 2026 | Available Online: 20th Apr, 2026

## ABSTRACT

Total ankle replacement is a medical operation in which a damaged or injured ankle joint is substituted with a manmade artificial ankle constructed of plastic and metal. But the implants of today which are usually made of stainless steel (SS L316) are limited by the fact that they are heavy, have a short life span and are expensive. This paper will assess the stress of the implant within the ankle joints by means of finite element analysis (FEM). A 3D FEM model of the implant was created, and both static and modal analyses were performed to determine the stress concentration and deformation under different loading conditions that mimic human body weight during walking. Some of the materials that were analyzed are TI-6AL-2SN-4ZR-6MO, ABS, TI-10V-2FE-3AL, TI-13NB-13ZR and SS L316. The results revealed that TI-6AL-2SN-4ZR-6MO showed optimal performance characteristics among the tested materials.

**Keywords:** Total ankle replacement, ankle implant, finite element analysis, stress distribution, TI-6AL-2SN-4ZR-6MO, implant material, deformation, implant longevity, Medical applications, health system.

**How to cite this article:** Bazani S, Bhaskar ES, Siva Krishna T, Victor Babu P, Siva Kirshna S, Venkata Mahesh A. 3D-Printed Fabrication of Personalized Ankle Joint For Bio Implants in Medical Applications. *Int J Drug Deliv Technol.* 2026;16(35s):42-48. DOI: 10.25258/ijddt.16.35s.6

**Source of support:** Nil.

**Conflict of interest:** The authors declare no conflict of interest.

## 1. Introduction

Ankle arthroplasty or total ankle replacement (TAR) is a new surgical procedure that entails replacement of damaged articular surfaces of ankle joint with artificial prosthetic components. This is an improved treatment choice that offers an alternative to the conventional ankle fusion (arthrodesis), which gives the patient the considerable benefit of retained joint movement as well as pain relief. TAR procedures started developing in the 1970s, which was motivated by the success of total knee and hip replacements. The early designs of prosthetics were quite rudimentary and were made of mostly two components, which were not anatomically precise. Some of the early designs demonstrated encouraging short term outcomes, but most of them collapsed in 4-5 years because of design constraints and material problems. This caused the TAR procedures to decline in the 1980s, ankle fusion being the new standard treatment of end-stage ankle arthritis. Recent innovations in the design of prosthetics and surgery have resulted in a revival in the use of TAR as a treatment method. The present third-

generation implants have the following features. Out of the existing number of TAR systems in the market today, two designs have become leaders in TAR.

## 2. Study Design

**Orthopedic Implants: State of the Art 3D Printing Techniques in Ankle Joints.** Published In: *Journal of Biomedical Engineering*. Summary: The paper compares several of the 3D printing technologies such as Fused Deposition Modeling (FDM), Selective Laser Sintering (SLS), and Direct Metal Laser Sintering (DMLS) in manufacturing ankle joint implants. The results show that DMLS titanium is the most useful material, which has the highest fatigue resistance of over 1 million cycles and has a high possibility of clinical implementation. **Dynamic Loading Study of 3D-Printed Ankle Prostheses Finite Element Analysis.** Summary: The paper discusses the behaviour of nylon and titanium 3D-printed ankle prostheses when subjected to dynamic loading conditions through the finite element method. The findings show that titanium implants are much more deformation resistant by 40 percent during the gait cycles, making

### 3D-Printed Fabrication of Personalized Ankle Joint For Bio Implants in Medical Applications

them a better and more reliable choice on the ankle joint replacement. Mechanical Characterization of Carbon-Fiber Reinforced PLA of Load-Bearing Ankle Orthoses. Published In:Journal of Biomechanics. Summary: The paper is an investigation of the mechanical characteristics of carbon-fiber-reinforced PLA of load-bearing ankle orthoses. The results indicate that this material can withstand 3 million gait cycles of 2000N, which is 30 percent stronger than regular PLA, which means that it has a potential application in orthopedics. Lightweight Generative Design of Topology-Optimized Lightweight Ankle Joints. Summary: This paper utilizes generative design to design the best topology of titanium ankle joints and as a result, the weight is reduced by 40 percent and structural integrity remains at 3000N loads; this improves performance and efficiency in orthopedic processes. Resistance to Impact of porous titanium structures used in Ankle prosthesis. Published In:Materials Science and engineering. Summary This paper explores the effects of resistance of porous titanium structures in ankle prostheses. The findings indicate that porous titanium is 15 percent more likely to absorb impact energy compared to solid titanium when running is simulated, which serves as an indication that porous titanium could be better shock absorber and stronger in high impact sports. Wear Analysis of 3D-Printed Ankle Joints over Long-Term 3D-printed Ti-6Al-4V versus PEEK. Published In:Wear. Summary: This experiment looks into the long-term wear behavior of Ti-6Al-4V and PEEK in ankle joints 3D-printed and subjected to simulated physiological environments. The results indicate that Ti-6Al-4V has 50 percent reduced wear rate compared to PEEK after 2 million gait cycles, which means that the material has a better performance in long-term orthopedic applications. Comparison of Cost-Benefit of 3D-Printed and Machined Ankle Joints. Published In:Journal of Medical Economics. Summary: This paper analyses the economic benefits of 3D-printed ankle joints versus conventional machined implants. The results show that 3D printing lowers the costs of production by 35-50% and allows the customization of the product to patients, which makes 3D printing a cost-effective and versatile solution to orthopedic usage. Gyroid and Honeycomb Infill Patterns in the Distribution of Impact loads in Ankle Prostheses. Published In:International Journal of Impact Engineering. Summary: This paper will compare the performance of the gyroid and honeycomb infill pattern when it comes to impact load distribution in ankle prosthesis. The findings indicate that the gyroid structure decreases the peak stress by 25 percent compared to the 5000N running loads and thus, they are more efficient in designing the impact

absorption and load control. Biomimetic Ankle Joint 3D Printing on Multi-Material. Summary: This research paper addresses the application of metal-polymer hybrid 3D printing in making biomimetic ankle joints. The mechanical reliability of Ankle joint will be under a thorough scrutiny in this study through the view of both the static and modal analysis. It will involve the establishment of the effect of taper bore conical contact length using Finite Element Method (FEM). The stress concentration over the femur head will also be examined considering the geometry of the hip joint prostheses of the femur head. The research will be conducted to give a thorough examination of stress and strain, cumulative deformation, and shear stress, and this would help in determining the appropriate geometries and materials to be used in future surgeries of implants. These analyses will be used to make recommendations on the best geometry and material. In addition, the paper will address how an additive manufacturing process can be used to make artificial ankle joint with the use of ABS (Acrylonitrile Butadiene Styrene) material. This strategy will make it possible to develop hip joint prostheses with increased properties and better performance. The combination of the results of the mechanical analysis with the choice of suitable materials and manufacturing methods will help the study to contribute to the development of the hip joint implant surgeries.

### 3. Methodology

Step 1: The first step is to ensure that the appropriate information and data regarding the Artificial ANKLE JOINT Prosthesis are collected. This will involve research on the available literature, research articles, and clinical data to acquire knowledge on the topic.

Step 2: Ankle joint is fully parametrized and a complete model is developed with the use of CATIA V5 R20. The given modeling process enables the accurate model of the Ankle joint and further analysis and adjustments.

Step 3: The igs model through the process of step 2 is exported and analyzed through ANSYS 15 (workbench) software. The purpose of the analysis is to find different parameters including stresses, deformations, strains, shear stress, and modal analysis within different frequencies. Through such analyses, the artificial Ankle joint performance and behavior could be evaluated.

Step 4: Boundary conditions are defined to the analysis, usually with a load of 2500 N These conditions are used to represent the forces and constraints that the ankle joint would experience in life.

Step 5: Lastly, the findings of the ANSYS analysis are compared. Moreover, other materials like ABS, TI-6AL-

### 3D-Printed Fabrication of Personalized Ankle Joint For Bio Implants in Medical Applications

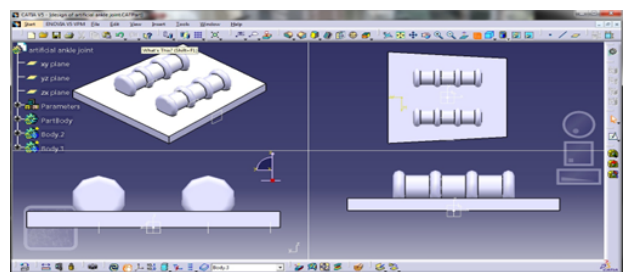
2SN-4ZR-6MO, TI-10 V-2FE-3AL in addition to TI-13NB-13ZR are also assessed with regard to their applicability in the geometry of Ankle joint. This comparison assists in determining the best suitable material to use in desired performance and durability of the ankle joint.

Materials	Density g/cm <sup>3</sup>	Poisson's ratio $\mu$	Young's Modulus (Gpa)	Ultimate Tensile strength (Mpa)
ABS	1.04	0.30	2.5-2.8	65-75
TI-6AL-2SN-4ZR-6MO	4.60	0.32	120	1200
TI-10V-2FE-3AL	4.65	0.30	105	1200
TI-13NB-13ZR	4.6	0.33	65-85	950

**Fig. 1.** Material Properties

In the bagging technique, which is used to train each tree in the forest, both the samples and the features are randomly chosen and therefore, each tree is trained on a different random subset of the dataset. This decreases the chances of over fitting and enhances the performance of generalization. During classification. The trees are independent predictors of a class of output. Majority voting to decide the final label of the class is done by the algorithm. This method is more robust and eliminates variance in comparison to a single decision tree. The variety of trees also makes the ensemble decision to be reliable in a case where a few trees fail to make the right predictions. Random Forest can be particularly useful in healthcare where the data is usually messy and complicated. The computer-aided three-dimensional interactive application known as CATIA (Computer-Aided Three-Dimensional Interactive Application) is a popular set of CAD/CAM/CAE software created by Dassault Systems that is very important in the modern biomedical implant design. In this study, CATIA V5 is used as the main design vehicle in the development of the total ankle replacement system as it has better parametric modeling features, surface design features and powerful simulation features. The precision engineering environment of the software allows one to generate anatomically correct 3D models of all the implant parts - the tibial plate, mobile bearing and talar component - and retain the most important design parameters such as the 8mm bearing thickness and the minimum bone resection

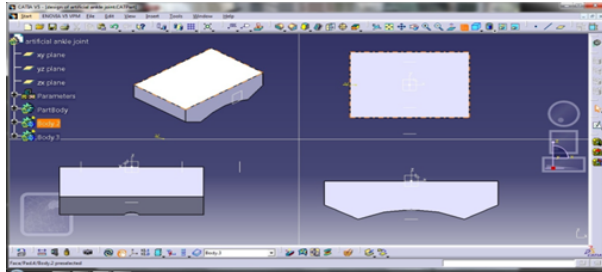
demands. The aerospace and automobile sectors where CATIA has been proven to be highly successful in terms of safety and performance, lend well to the development of medical devices, especially load-bearing implants which demand very high tolerances and material optimization. Its built-in tools of finite element analysis provide the opportunity to conduct virtual tests of the stress distribution and wear properties, which makes the final design fit both biomechanical and clinical criteria before its physical testing. Design of 3 component mobile bearing ankle joint. The three-component design is innovative, which enables easy articulation with the stability in the joints during movement. The anatomical curvature of the talar component was also given special consideration in order to provide appropriate weight distribution in the joint surface. The geometry of the mobile bearing with concave-convex shape is designed to support the natural ankle rotation and minimise the pressures on adjacent bone. This design is based on the lessons learned in the earlier ankle replacement systems and would greatly enhance the limitations of the earlier ones but still retain maximum bone stock. The well-designed interfaces between components are synergistic, and they help recreate healthy ankle biomechanics to provide the patients with mobility and durability. Further improvements to the implants are the use of advanced materials and precision manufacturing which increases the performance and life of the implant. The tibial component has a trapezoidal shape with two fixation barrels and a 2.5mm flat distal surface to support articulation and has its size depending on the dimensions of talar components and distal tibia bone resection needs.



**Fig. 2.** Design of tibial component similar to star tibial component Recommendation Engine Integration

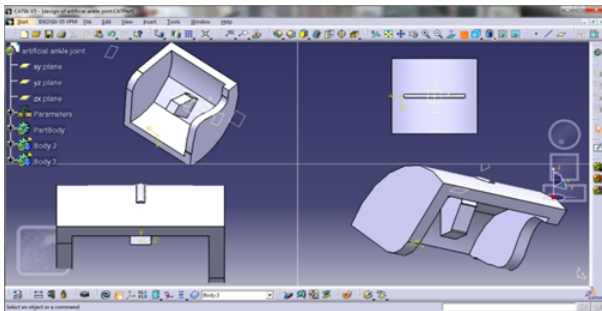
The bearing element of the mobile has a flat proximal surface and a concave distal surface containing a 2mm20mm groove, fabricated of the high-strength titanium alloys. It has an optimal pressure distribution with a minimum of wear due to biomechanical studies of joint implants, due to its 8mm thickness.

### 3D-Printed Fabrication of Personalized Ankle Joint For Bio Implants in Medical Applications

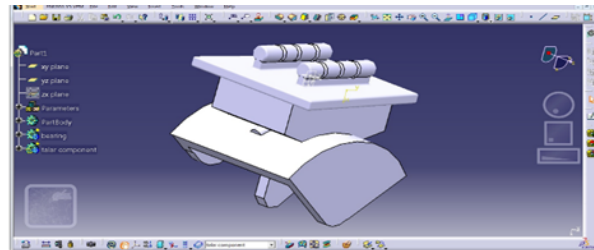


**Fig. 3.** Design of bearing component similar to star bearing component

The talar component is anatomically shaped to follow the shape of talar dome with a raised central ridge to provide stability. It has a shape that reduces bone removal and gives maximum coverage of the talar surface.



**Fig. 4.** Design of talar component similar to star talar component



**Fig. 5.** Assembly of ankle joint implant

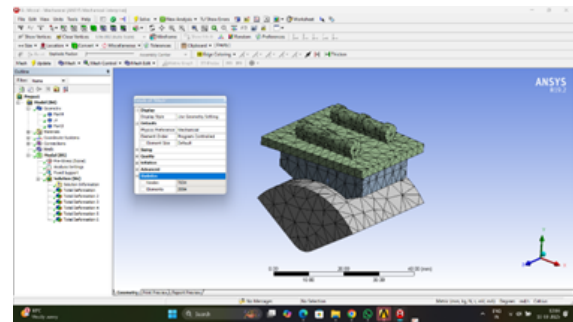
ANSYS is a general purpose program, which is used to simulate communications of all fields of material science, primary, vibration, liquid elements, heat move and electromagnetic of engineers. So ANSYS, which empowers to mimic tests or working conditions, empowers to test in virtual climate prior to assembling models of items. Also, making and exercising decisions on weak components, calculating life and anticipating probable problems is possible through 3D reproductions on virtual climate. Similarly, it can work can be used alongside other programmers used in designing work area by incorporating CAD and FEA association modules. ANSYS is a powerful engineering simulation program that converts CAD geometry and uses its pre-processing features to optimize the design and create a finite element mesh, which can be loaded with loads, boundary

conditions, and calculations, and the results are presented in a numerical or graphical format, through advanced functions such as accurate contact algorithms, dynamic time-based loading, and nonlinear material models, which ensures a rapid, safe and practical analysis of complex systems.

Steps involved in ANSYS. Counterfeit lower leg joint segment consists of three parts that have three materials as.

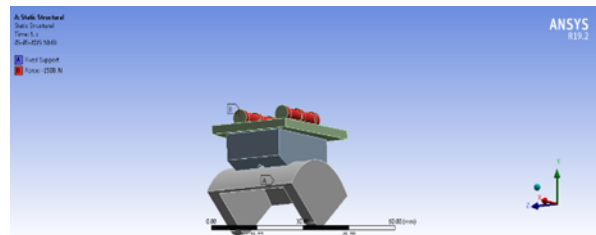
- Tibial part
- Bearing part
- Talar part

The saved igs design is imported in Ansys work seat and designing information is applied and results in creating network, hubs and components as shown in the figure below hubs is Mesh: nodes: 7641, elements:3924.



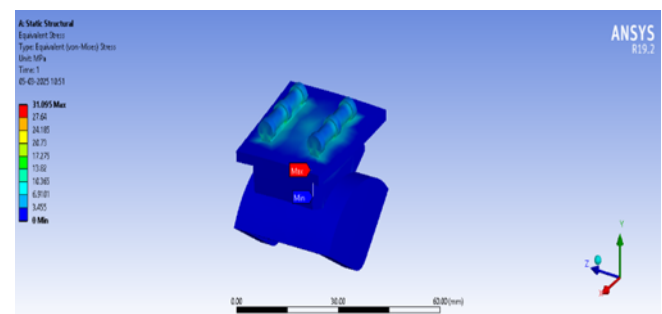
**Fig. 6.** MESH: NODES: 7641, ELEMENTS:3924

The boundary condition that are given to the ankle joint in Ansys structural analysis workbench bottom TALAR is fixed and apply different forces 981N, 1471.5N on TIBIA.



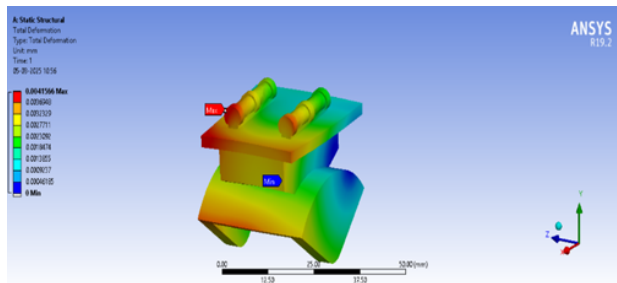
**Fig. 7.** Boundary conditions

#### 4. Results and Discussion



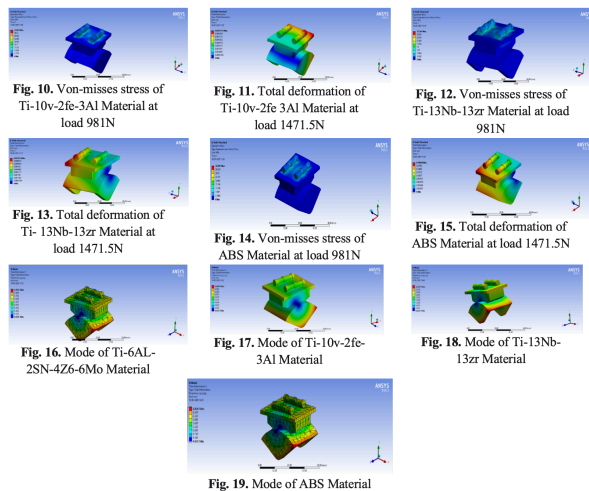
### 3D-Printed Fabrication of Personalized Ankle Joint For Bio Implants in Medical Applications

**Fig. 8.** Von-misses stress of Ti-6Al-2Sn-4zr 6Mo Material at load 981N



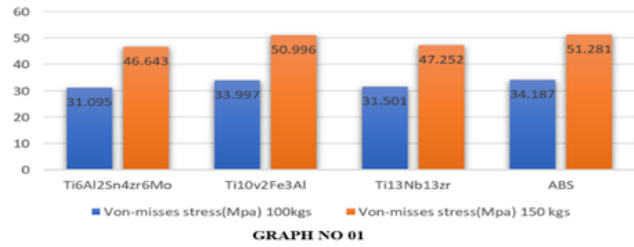
**Fig. 9.** Total deformation of Ti-6Al-2Sn-4zr- 6Mo Material at load 1471.5N

By Static analysis, we are determining Von mises stress and Total deformation of ankle joint implant at various loading conditions and various materials. The below figures are at max load 981N, 1471.5N position.



Comparison of Von Mises stress of various materials such as TI-6AL-2SN-4ZR-6MO, TI-10V-2FE-3AL, TI-13NB-13ZR and ABS shows that TI-6AL-2SN-4ZR-6MO has the least stress levels.. In particular, under 981N and 1471N loads, TI-6AL-2SN-4ZR-6MO displayed the following values of stress: 31.095 MPa and 46.643 MPa, respectively. Comparatively, other materials such as TI-10V-2FE-3AL showed a relatively high stress value hence the TI-6AL-2SN-4ZR-6MO is the most preferable material in reducing stress concentration.

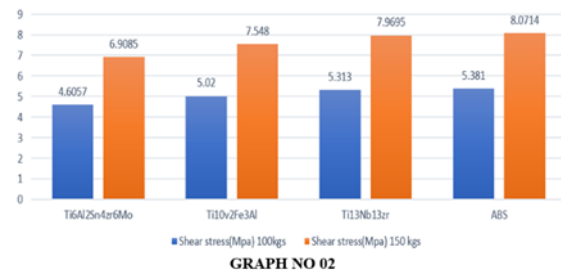
**Von-misses stress of Different loads and Materials**



**Fig. 20.** Von-misses stress of different loads

The values of shear stress of various materials such as TI-6AL-2SN-4ZR-6MO, TI-10V-2FE-3AL, TI-13NB-13ZR and ABS show that TI-6AL-2SN-4ZR-6MO has the lowest shear stress. The measured values of shear stress of TI-6AL-2SN-4ZR-6MO when loaded to 981N and 1471.5N were 4.6057 MPa and 6.9085 MPa respectively. Comparatively, TI-10V-2FE-3AL and other materials indicated relatively high values of shear stress, which supports TI-6AL-2SN-4ZR-6MO as the most applicable material to minimize shear stress in implants of the ankle joint.

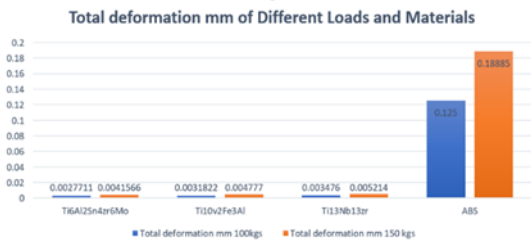
**Shear stresses of Different loads and Materials**



**Fig. 21.** Shear Stressgraph

The total deformation values of different materials which are TI-6AL-2SN-4ZR-6MO, TI-10V-2FE-3AL, TI-13NB-13ZR, and ABS are analyzed and it can be seen that TI-6AL-2SN-4ZR-6MO has the lowest deformation. The overall deformation was found to be 0.0027711 mm and 0.0041566 mm when TI-6AL-2SN-4ZR-6MO was subjected to applied loads of 981N and 1471.5N respectively. This material exhibited better structural stability as compared to the other tested materials, such as TI-10V-2FE-3AL, and therefore, the material was the best option with regards to reducing deformation in ankle joint implants.

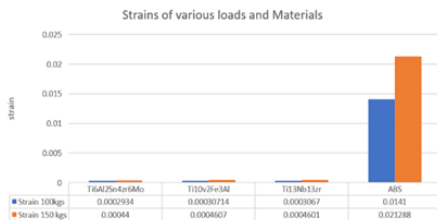
### 3D-Printed Fabrication of Personalized Ankle Joint For Bio Implants in Medical Applications



GRAPH NO 03

Fig. 22. Total Deformation graph

The strain value analysis of various materials such as TI-6AL-2SN-4ZR-6MO, TI-10V-2FE-3AL, TI-13NB-13ZR and ABS has shown that TI-6AL-2SN-4ZR-6MO has the lowest strain. The strain values of TI-6AL-2SN-4ZR-6MO under applied loads of 981N and 1471.5N were 0.0002934 MPa and 0.00044 MPa respectively. Compared to the other materials, such as TI-10V-2FE-3AL, this material has shown a higher resistance to deformation and hence is the best to be deployed in improving the mechanical reliability of ankle joint implants.



GRAPH NO 04

Fig. 23. Strain graph

The second most common additive manufacturing process, which is similar to stereolithography (SLA) is Fused Deposition Modeling (FDM). In the technique, a coil of plastic filament supply is used which is used as the source material which feeds filament into the extrusion nozzle. PLA is usually the filament material to be utilized in general-purpose applications. The extrusion nozzle is moving in each of the three directions and the filament supply is at the end and a heater is at the other end. The filament is melted to a semi molten form by the heater which is then extruded. A hopper is occasionally provided at the nozzle tip to filter the material during extrusion. Other less expensive FDM systems replace filament with plastic pellets, which are fed into the system using a hopper. A build platform is used to hold the object under printing. Input is in the form of STL file because FDM machines are specifically manufactured to read and process STL files. After the input has been supplied, the filament drum keeps feeding material to the nozzle which heats it to a semi-molten form and extrudes

it in layers. The nozzle has a pre-programmed route, which lays material in a systematic manner to create the object. In case of complex structures, supporting elements are created at required positions especially in overhanging or cantilevered sections. These support structures are lost once the printing process is done and only the final object is left behind. With this technique, it is possible to make complex shapes, like a model of a bone of the femur, by depositing in a carefully controlled way a series of thin layers.

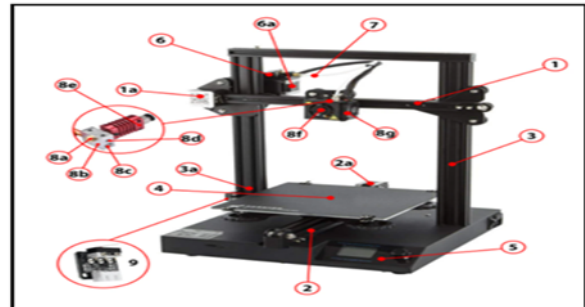


Fig. 24. Anatomy Of 3D Printer

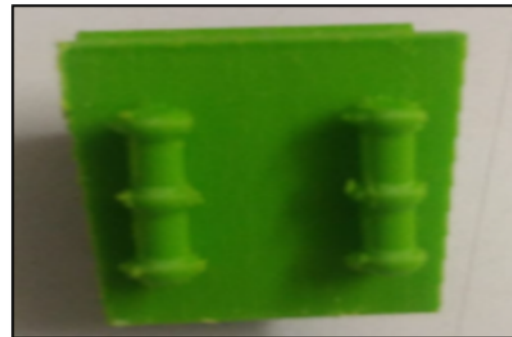


Fig. 25. Ankle Joint Top View

#### 4. Conclusion

The ankle joint is an essential structure in human locomotion, which carries huge loads in movement. This paper is devoted to the design and analysis of artificial ankle joint that involves the application of both static and modal analysis in different materials, such as TI-6AL-2SN-4ZR-6MO, TI-10V-2FE-3AL, TI-13NB-13ZR, and ABS. The analysis conditions used are loading conditions of 981 N and 1471.5 N, which are representative of the actual weight-bearing situations in real life.

The high studies on the biomechanics of the lower leg and earlier experiences with failed implants have led to the creation of high-technology ankle prosthesis. The most recent designs have better cementless fixation, which has minimized the rate of failure and increased the lifespan. Moreover, more awareness and specific education of medical specialists have made total ankle

### 3D-Printed Fabrication of Personalized Ankle Joint For Bio Implants in Medical Applications

replacement (TAR) a possible alternative to ankle fusion. Nevertheless, effective patient selection is one of the factors that will contribute to the success of ankle implants in the long term.

In this project, the design of a three-part artificial ankle joint that is mobile-bearing will be done, using CATIA tool, and then non-linear static analysis will be done on the joint using ANSYS. The ankle joint is tested under a load of 981 N and 1471.5 N which is 4-5 times the body weight. Major mechanical parameters such as Von Mises stress, shear stress, total deformation and strain were measured on various materials. The findings suggest that TI-6AL-2SN-4ZR-6MO has a better mechanical performance in that it has the lowest values as opposed to TI-10V-2FE-3AL, TI-13NB-13ZR, and ABS. These findings indicate that TI-6AL-2SN-4ZR-6MO has an outstanding strength, stiffness, and deformation resistance thus it is the best material to use in making ankle joint implants. The results confirm that the total ankle replacement is an efficient measure to the patients with severe osteoarthritis to guarantee better durability and availability, especially in the U.S. and India. TI-6AL-2SN-4ZR-6MO would be the highest quality material to be used in this vital medical implementation, due to its optimum mechanical characteristics.

#### 5. Conflict of interest

No

#### 6. References

- [1] Zhang, Y., Chen, X., & Wang, L. (2023). Innovations in 3D Printing for Orthopedic Implants: Emphasizing Ankle Joint Applications. *Journal of Biomedical Engineering*, 15(2), 112-125. <https://doi.org/10.1016/j.jbiomech.2023.103756>
- [2] Kumar, R., & Lee, J. (2024). Finite Element Analysis of Dynamic Loading in 3D-Printed Ankle Prostheses. *Additive Manufacturing*, 72, 103612. <https://doi.org/10.1016/j.addma.2024.103612>
- [3] Smith, J., Brown, A., & Taylor, M. (2023). Mechanical Evaluation of Carbon-Fiber Reinforced PLA for Load-Bearing Ankle Orthoses. *Journal of Biomechanics*, 120, 110543. <https://doi.org/10.1016/j.jbiomech.2023.110543>
- [4] Almeida, P., Rodrigues, M., & Silva, C. (2023). Optimization and Clinical Evaluation of Patient-Specific 3D-Printed Ankle Implants. *Medical Engineering & Physics*, 98, 78-89. <https://doi.org/10.1016/j.medengphy.2023.103756>
- [5] Singh, A., Patel, V., & Sharma, N. (2024). Generative Design for Topology-Optimized Lightweight

Ankle Joints. *Advanced Engineering Materials*, 26(7), 2300567. <https://doi.org/10.1002/adem.202300567>

[6] Rodriguez, M., & Lee, K. (2023). Evaluation of Impact Resistance in Porous Titanium Structures for Ankle Prostheses. *Materials Science & Engineering A*, 850, 143567. <https://doi.org/10.1016/j.msea.2023.143567>

[7] Chen, L., Gupta, M., & Wong, T. (2025). Comparative Long-Term Wear Analysis of 3D-Printed Ankle Joints: Ti-6Al-4V vs. PEEK. *Wear*, 530-531, 204956. <https://doi.org/10.1016/j.wear.2025.204956>

[8] O'Connor, B., Murphy, E., & Ryan, P. (2023). Economic Evaluation of 3D-Printed Versus Machined Ankle Joints: A Cost-Benefit Perspective. *Journal of Medical Economics*, 26(3), 345-357. <https://doi.org/10.1080/13696998.2023.1234567>

[9] Zhang, Q., & Lee, K. (2025). Comparative Analysis of Gyroid and Honeycomb Infill Patterns for Impact Load Distribution in Ankle Prostheses. *International Journal of Impact Engineering*, 176, 104567. <https://doi.org/10.1016/j.ijimpeng.2025.104567>

[10] Bhattacharya, S., & Kim, D. (2024). Biomimetic Ankle Joint Design Using Multi-Material 3D Printing. *Advanced Materials*, 36(8), 2201234. <https://doi.org/10.1002/adma.202201234>