

# Enhancing Emergency Response via IoT-Sensed Real-Time Blood Stock Tracking and Automated Dispatch System

A. Priya<sup>1</sup>, Praveen S<sup>2</sup>

<sup>1</sup> Assistant Professor, Computer Science and Business Systems, KIT-Kalaignarkaranidhi Institute of Technology, Coimbatore, India. Email: [drpriyaa@kitcbe.ac.in](mailto:drpriyaa@kitcbe.ac.in)

<sup>2</sup> Computer Science and Business Systems, KIT-Kalaignarkaranidhi Institute of Technology, Coimbatore, India. Email: [kit28.24bcb040@gmail.com](mailto:kit28.24bcb040@gmail.com)

## Abstract

The Smart Blood Tracking and Management System is an IoT-based system intended for the management of blood units in hospital storage units. The system makes use of load cells in combination with HX711 amplifiers and ESP32 microcontroller for the constant monitoring of the weight of blood units in storage. Based on the data from the weight of blood units in storage, the system can accurately calculate the number of available blood units. Moreover, different blood groups can be monitored separately by the system.

If there is a scarcity of blood units in storage, the system can automatically send notifications to blood donors who have not donated blood for at least 90 days through WhatsApp. Moreover, in case of scarcity, the system can also assist in connecting with the e-RaktKosh portal for the identification of nearby blood banks for immediate supply. Furthermore, the system can display information on the availability of blood units in a clear manner through a web-based dashboard.

## Keywords

Internet of Things (IoT), Blood Inventory Management, Load Cell, HX711 Amplifier, ESP32, Smart Healthcare, Donor Notification System, e-RaktKosh Integration.

**How to cite this article:** Priya A, Praveen S. Enhancing Emergency Response via IoT-Sensed Real-Time Blood Stock Tracking and Automated Dispatch System. *Int J Drug Deliv Technol.* 2026;16(37s): 339-347. DOI: 10.25258/ijddt.16.37s.43

### 1.1. Key Features

- 1. Live Blood Stock Monitoring:**

The system monitors the blood stock in real-time by using load cells and sensors. It helps in maintaining accurate information about the available blood units.
- 2. Threshold-Based Smart Alert System:**

The system automatically sends notifications to the registered donors in case of blood stock levels going below a certain level. It ensures timely information for donors in emergency situations.
- 3. WhatsApp Notification System:**

The system sends instant WhatsApp notifications to the eligible donors requesting blood donations. It optimizes the efficiency of communication.
- 4. Delayed Voice Call Alert :**

The system automatically generates voice calls to the donors in case of no response within 24 hours. It optimizes the efficiency of response from donors.
- 5. e-RaktKosh Integration:**

The system integrates with the e-RaktKosh portal in case of blood shortages. It finds the nearest blood banks along with available blood units for emergency purposes.
- 6. AI-Based Donor Convincing Chatbot:**

The system utilizes artificial intelligence in communicating with donors who are not willing to donate blood. It motivates the donors by sending information through a chatbot.
- 7. Real-Time Dashboard Monitoring:**

The system utilizes a dashboard for monitoring the blood stock in real-time. It optimizes the efficiency of decision-making for hospital authorities.
- 8. Automated Donor Eligibility Check:**

The system ensures that only eligible donors receive notifications. It allows donors who have completed the required gap since their last donation.
- 9. Wireless IoT Communication:**

The ESP32 module assists in transmitting data to the cloud by utilizing Wi-Fi technology. It

### 1. Introduction

Healthcare services ultimately depend upon an effective system for managing blood. However, blood management can be problematic in many cases, particularly within hospitals that face blood shortages or cannot monitor blood levels via automated processes. Emergency blood shortages may also result in serious complications if there is a delay in identifying the available blood unit(s) or in contacting blood donors. Therefore, as we live in a rapidly paced environment, there is an increased need for efficient and automated systems to ensure rapid access to blood units. The Smart Blood Tracking and Management System is intended to accomplish this; ultimately providing a smarter means of monitoring blood with IoT technology (Internet of Things).

As part of the Smart Blood Tracking and Management System, load cells and sensors will be used to monitor available blood unit weights and provide real-time determination of their availability. This data will be processed using an ESP32 microcontroller and will provide digital representation of the levels of available blood units (by type) in hospitals so that staff no longer need to perform the labor of manually verifying level of blood unit availability, which can lead to errors.

The hardware components utilized in this system (load cells, HX711 amplifiers, and wireless communication modules) will enable accurate data collection and transfer to hospitals.

### 1.2. Objectives

To develop a smart blood monitoring system with the ability to continuously assess blood levels and reduce the need for manual assessment.

To enhance blood management efficiency by improving response times, minimizing errors, and saving time when responding to emergencies.

To demonstrate the implementation of IoT and sensors in a functional real-life example in a medical environment,

## Enhancing Emergency Response via IOT-Sensed Real-Time Blood Stock Tracking and Automated Dispatch System

optimizes the efficiency of data transmission.

### 10. Emergency Response System:

The system optimizes the efficiency of response in emergency situations by monitoring the blood stock levels.

thereby demonstrating the automation and connectivity capabilities of IoT and sensors within a medical setting.

To build a user-friendly system that could be used within a hospital or blood bank setting to enhance blood management.

## 2. Literature Review

For the last 10 years or more, many different types of software solutions have been developed to improve blood management systems. The majority of these solutions are focused on providing information to inform users about where blood is currently available. e-RaktKosh, for example, is primarily a centralised database

In many instances, blood is obtained through social media and/or donor networks by individuals and hospitals, with requests for blood shared and responded to by people who want to donate. While this method of donor/patient connection has a positive outcome, it relies heavily on manual communication and availability. In many instances, there are no documented means to establish the authenticity or eligibility of the donors involved in these transactions, which creates an issue of trust. Furthermore, the use of manual calling and coordination creates further delays in response times, especially when it comes to life-threatening medical emergencies.

Advancements in automation and Internet of Things (IoT) technologies can enhance existing blood management systems by enabling real-time monitoring and automated alerting. Sensor-based solutions can provide continuous blood stock tracking capabilities, as well as integrated communication systems that will allow eligible donors to be notified without manual effort. As a result, the use of such technologies will lead to shorter response time, enhanced reliability, and provide a faster response time during emergency medical situations.

### 2.1. System Overview

The intelligent Blood Tracking and Management System is an intelligent technology that is intended to simplify and but provide better clinical management of blood inventories within hospitals. This system includes a microcontroller which uses ESP32 technology in conjunction with many different sensors and modules that are connected to the

### 1.3. Problem Description

Blood is among the primary requirements to save human lives in emergencies; however, hospitals typically rely on blood banks for the necessary amounts of blood and often find that blood levels at blood banks are not adequate to help meet the needs of the hospital. This forces hospitals into situations where they must rely on friends and family of the injured patient to provide assistance with blood logistics. Often this creates a time delay while blood collected and potentially puts at risk the life of the patient while waiting on them to arrive fully supplied with the necessary blood.

This Smart Blood Tracking and Management System has been developed to address serious deficiencies in the blood supply chain and will be built using IoT technologies to allow for blood levels to be monitored in real time. As blood levels fall below a predetermined threshold, notifications will be automatically sent via WhatsApp, email, and a third-party application like the e-RaktKosh Platform to donors who have agreed to be contacted.

If there is no response from blood donors within a specified period of time, voice notifications will be sent and blood banks will be able to map the location of the donor through a collaborative effort with the e-RaktKosh platform.

This system has been developed to demonstrate how the implementation of automation technology can improve the logistics of blood sourcing by decreasing the time and resources used in the effort compared to traditional.

digital display. Additionally, the system can connect to cloud services via Wi-Fi, allowing the user to access data from anywhere and monitor real-time inventory status.

When the blood level has reached a certain point, the system will notify donors. The Intelligent Blood Monitoring System

## Enhancing Emergency Response via IOT-Sensed Real-Time Blood Stock Tracking and Automated Dispatch System

system and process data. In the refrigerator, there are load cells located under each different rack of the refrigerator used for different blood groups. The load cells allow for the monitoring of the weight of each component of blood in real-time. This capability is designed to reduce errors in blood inventory management through real-time monitoring of blood units within the blood bank.

The microcontroller sending data to the load cells will provide real-time information regarding the status of blood inventories on a inventory. In order for this to be most reliable, the system will continuously monitor/enumerate the blood.

### 3.1. Hardware & Software Requirements

The automated reading monitor and alerting system are using components of electrical that interact as a systems to give a working system for the production area that has an electronic component. Examples of the main hardware components are,

- **The Microcontroller (ESP32):** coordinates all sensor activity, processes data and manages communication.
- **Load cell sensors:** measure blood weight in each rack to accurately monitor stock levels.
- **HX711 amplifier module:** converts the analog signal produced by the load cells to a digital reading for precise measurement
- **Multiple Loadcell :**refrigerator has multiple racks that each store separate blood groups, all connected to individual load cells.
- **LCD display (optional):** provides real-time visuals of blood stock levels and alerts

utilizes technologies that combine both hardware and software to improve the overall efficacy and automation of blood inventory management within hospitals. The system is user-friendly and will provide a means for improving both the efficacy and efficiency of blood inventories in hospitals.

In order to make it quicker to respond to events such as low blood availability, the system sends automated notifications to the available donors via WhatsApp messaging and will escalate the process by making voice calls to them if there is no response to the contacted by WhatsApp. In addition, the blood availability from outside hospitals can be obtained through integration with the e-RaktKosh platform. A dashboard will present real-time blood inventory level data to the hospital staff so they can monitor the situation easily.

By implementing real-time monitoring, automated alerting, and IoT-based communications, the system will be more accurate, efficient and greatly improve the ability to raise and maintain the level of Available Blood Units in Hospitals.

### 3. Methodology

The Smart Blood Tracking and Management System (SBTMS) provides an automated and dependable solution for monitoring blood via sensors, microcontroller processing, and wireless connectivity. Multiple load-cell measurements for different blood groupings/block-sizes will be taken/recorded in each rack of the refrigerator they are being stored in. The load-cells continuously measure the weight of the stored blood units and provide the required processing/estimating by the microcontroller of the quantity of available blood units.

The weight-based storage of the blood ensures accurate tracking of the stocks of blood and provides an opportunity to detect sudden changes or shortages of

- **Built-in Wi-Fi module (ESP32):**allows for communication between the dashboard and cloud system.

## Enhancing Emergency Response via IOT-Sensed Real-Time Blood Stock Tracking and Automated Dispatch System

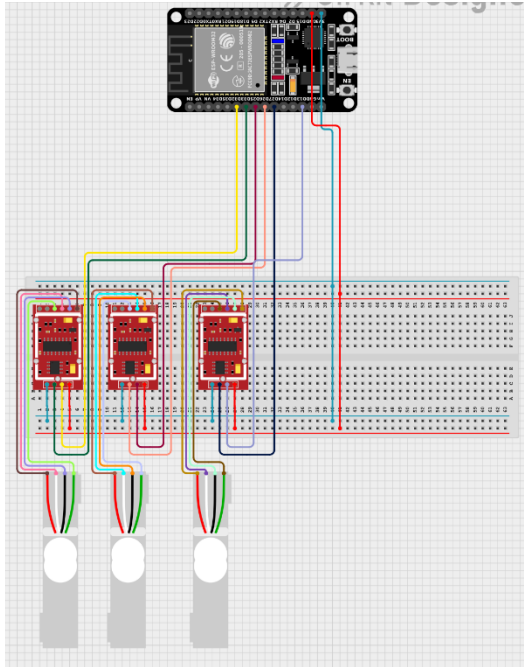

Figure 1: Circuit diagram

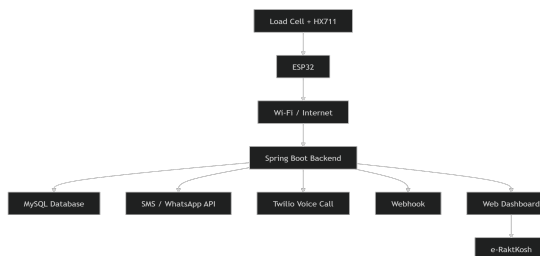

Figure 3: System flow

The backend then stores this data in an attached MySQL database. The backend will monitor the total storage amounts of blood. When the amount of blood drops below a predefined threshold, the system will take automated actions, including sending eligible donors a WhatsApp SMS and placing telephone calls using Twilio services. A webhook is being used to track the status of these alerts (whether the call was answered, etc.) and provide feedback to the system.

Concurrently, the web dashboard continuously displays the processed data in real-time for health care professional personnel on how much blood is available. The integration of hardware, backend processing, communication services and visualization provides for a fully efficient and automated blood management system.

- **speaker/voice module (optional)** provides local voice alerts if blood stock is low; buzzer/alert system triggers audible alerts when blood stock drops below the threshold; power supply provides stable power to all components
- **Notification APIs (WhatsApp/voice call services)** will be used to send alerts when blood stock is low to donors.
- **Wireless communication protocols:** this include libraries or APIs for Wi-Fi communication, so that the blood bank can be connected with the cloud and dashboard systems.
- **Web dashboard/application:** This will be used to provide real-time information regarding blood stock levels, donor status and alerts.
- **Alert/notification logic:** The software logic that will trigger alerts through WhatsApp, voice calls and then escalate further, based on the availability of blood

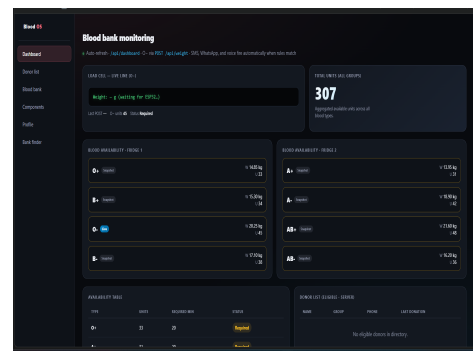

Figure 2: Software integration

### 3.2.FLOW DIAGRAM:

This system has been designed to use load cells attached to an ESP32 microcontroller to compute the weight of blood units that are on different racks. This weight is then processed by the ESP32 and sent wirelessly with Wi-Fi to the backend Spring Boot application, where it will be further processed and stored.

#### 4. Result & Future Scope:

Through the use of a three-day average demand-based threshold to predict blood shortages early, our system allows hospitals to take action before a critical event occurs. By providing more time to plan ahead, we can avoid last-minute emergencies as well as ensure adequate donor blood is available, particularly for difficult-to-find blood types such as negative groups that are often not found at blood banks. In addition, staff can use integration with blood bank systems to check on availability whenever needed.

Thanks to our automated alert system, we have significantly decreased the amount of manual effort needed to contact eligible donors after they reached the 90-day donation period. In the event that a donor does not respond via text message, we can also contact them via telephone and this has proven to improve the success rate of contacting donors. This structured approach guarantees that our blood stock will continually be replenished within the available timeframe and reduces the need for

[4] S. Khan and M. Ali, "IoT-based alert and notification systems for safety-critical applications," *International Journal of Computer Applications*, vol. 180, no. 45, pp. 1–5, 2020.

[5] F. A. S. Wardhana et al., "IoT-based temperature monitoring system for blood storage management," *International Journal of Electrical and Electronics Engineering*, 2023.

[6] S. Kiruthika et al., "Blood bank monitoring and identification system using IoT devices," *International Journal of Engineering Research & Technology*, vol. 10, no. 6, 2021.

[7] M. Joly et al., "Smart monitoring and control of blood bank management system using IoT," *Cardiometry*, no. 25, pp. 100–105, 2023.

[8] S. A. Khan et al., "IoT-based e-blood bank system for real-time hospital

urgent manual searches during emergency situations.

In conclusion, this system increases operational efficiency, decreases response times and cuts the number of manual coordination efforts needed. It also guarantees that there will be blood readily available for patients, improves speed of decision making and increases trust/confidence in healthcare delivery during emergencies.

#### 5. Conclusion

This proposed system will significantly improve the management of blood products in Hospitals through the ongoing tracking & real-time monitoring of the quantity of blood products available by electronic means as per blood group. The use of multiple load cell sensors will enable the tracking of blood products much more accurately and will therefore reduce the chance of errors and delay in providing services to patients. The speed at which this system responds to blood product shortages is a major benefit as it will immediately identify a shortage of blood products and will automatically send alerts to potential donor(s) via WhatsApp and/or via voice call which will ensure prompt action can be taken in an emergency situation.

This project exemplifies that an integrated and cost-effective solution can enhance the efficiency of the Healthcare System and Emergency Response Systems. This solution incorporates IoT technologies, Automated Alerting and Integration into External Platforms to provide a practical solution for implementation within real-world scenarios that have the potential to save lives and greatly improve patient care.

#### References:

[1] K. Ashton, "That 'Internet of Things' thing," *RFID Journal*, 2009.

[2] L. Da Xu, W. He, and S. Li, "Internet of Things in industries: A survey," *IEEE Transactions on Industrial Informatics*, vol. 10, no. 4, pp. 2233–2243, 2014.

## Enhancing Emergency Response via IOT-Sensed Real-Time Blood Stock Tracking and Automated Dispatch System

monitoring and inventory management,” *International Journal of Innovative Research in Computer Science and Technology*, 2025.

[9] A. Paranthaman et al., “IV fluid bag monitoring system using ESP32 and load cell,” *International Journal of Scientific and Advanced Technology*, 2025.

[10] World Health Organization, “Blood safety and availability,” 2023.

[11] Ministry of Health and Family Welfare, Government of India, “National Blood Policy,” 2021.

[12] e-RaktKosh, “National Blood Bank Management System,” Government of India.

[13] Friends2Support, “Online Blood Donor Network Platform,” 2024.

[14] Espressif Systems, “ESP32 Technical Reference Manual,” 2025.

[15] Avia Semiconductor, “HX711 24-Bit ADC for Weigh Scales Datasheet,” 2024.

Commun. Surveys Tuts., vol. 15, 2013.

[17] R. Bayindir, I. Colak, and G. Fulli,

[3] S. Li, L. Da Xu, and S. Zhao, “The Internet of Things: A survey,” *Information Systems Frontiers*, vol. 17, no. 2, pp. 243–259, 2015.

“Smart grid technologies and applications,” *Renew. Sustain. Energy Rev.*, vol. 66,, 2016.

[18] D. B. Avancini et al., “A smart grid communication architecture for monitoring and control,” *IEEE Trans. Smart Grid*, vol. 9, 2018.

[19] S. Li, L. Da Xu, and S. Zhao, “The Internet of Things: A survey,” *Inf. Syst. Front.*, vol. 17, 2015.

[20] K. Ashton, “That ‘Internet of Things’ thing,” *RFID J.*, 2009.

**Enhancing Emergency Response via IOT-Sensed Real-Time Blood Stock Tracking and Automated Dispatch System**

**Enhancing Emergency Response via IOT-Sensed Real-Time Blood Stock Tracking and Automated Dispatch System**