

A Noval Antenna Absorber For Breast Cancer Detection And Tracking Targeted Drug Delivery

Jaimini shah¹, Parikshit Vasisht¹, Yatin vasisht²

¹*School of Engineering and Technology, Apeejay Stya University, Sohna, Gurugram.*

Email: jaimini.shah@asu.apeejay.edu, parikshit.vasisht@asu.apeejay.edu

²*Staff Cybersecurity Engineer, Costco*

Email: Yatin.vasisht@gmail.com

ABSTRACT

In this work, a small multilayer metamaterial patch antenna for microwave breast imaging (MWI) like breast cancer detection and targeted drug delivery applications was developed both theoretically and experimentally. However, to improve the antenna performance relating to the bandwidth (BW), the radiating element of the suggested initial antenna is modified by adding a modified split ring resonator (SRR) and slits in the patch as well as the ground plane. Then, to achieve the requisite antenna properties for MWI applications such as the gain and directivity, the antenna is equipped with a uniplanar artificial magnetic conductor (AMC) has a relatively small size of $30 \times 30 \times 1.6$ mm³ and it accomplishes a return loss below -40 dB ($S_{11} < -40$ dB) at overall BW of 7 GHz with more than 5 dBi realized gain. In this way, the characteristics of the fabricated antenna are measured to examine the antenna performance. Indeed, the fidelity factor of face-to-face and side-by-side scenarios are also noticed for the same frequency range. In the final analysis, a simulation model of the antennas, which operate as a transceiver, and a breast phantom model with tumor sample are proposed for detecting cancerous tumor cells within the breast cell. Hence, the proposed design is suitable in the biomedical applications such as tumor cell detection and drug delivery technology

Keywords: Metamaterial, Split Ring Resonator(SSR), Negative Permittivity(ϵ), Negative Permeability(μ), Complimentary split ring resonator(CSRR), Negative Refraction, microstrip antenna (MSA), frequency band width(FBW).

How to cite this article: Shah J, Vasisht P, Vasisht Y. A Noval Antenna Absorber For Breast Cancer Detection And Tracking Targeted Drug Delivery. *Int J Drug Deliv Technol.* 2026;16(62s): 1936-1944. DOI: 10.25258/ijddt.16.62s.194

Source of support: Nil.

Conflict of interest: None.

1. INTRODUCTION

A microstrip patch antenna consists of a conducting patch and ground plane, and between them is a dielectric medium called the substrate, which has a particular value of dielectric constant with a small dimension of a patch. Metamaterials, or artificial structures with negative permittivity and negative permeability, were first studied in 1968 by Veselago, which are formed by a triad of vectors: electric field, magnetic field, and phase propagation. The effects of metamaterials can be observed during the wave propagation. Metamaterials can be used for microwave band frequencies, terahertz field frequencies, and ultra-wideband band frequencies in devices such as antennas, filters, and integrated network sensors that can improve some of the parameters of equipment in the different fields of communication and technology. To improve the radiation properties of the antenna by using metamaterial surfaces, antennas are often placed above the reflector in order to radiate in a specific direction only while reducing the back-radiation.

The distance between the antenna and the metal surface should be chosen to be a minimum of $\lambda/4$, where the metamaterial acts as a reflective plane to enhance the radiation pattern and radiation efficiency. The

complementary split-ring resonator (CSRR) antennas have received growing attention due to their numerous remarkable characteristics, such as low profile, high radiation efficiency, broadband characteristics, light weight, and stability for high-frequency applications. In addition, the realization of split ring resonators (SSRs) in various geometrical shapes along with simple feeding mechanisms such as inset, offset, coaxial probe, aperture coupling, coplanar feed, slot line, etc. Typically, CSRRs are well suited for low-loss wireless applications on account of infinitesimal conductor losses and high impedance.

In early decades SRRs were recognized as radiating elements, beginning with the analysis of basic shapes such as rectangular, circular, and cylindrical. Fundamentally, a typical existing structure such as a CRLH-based antenna provides a gain of 3.16 dBi with an antenna efficiency of 76.5% and with an FBW of 1.52% at a very high resonant frequency. A circularly polarized patch antenna (CRLH-based) has a gain of 3 dBi with 70% efficiency. A metamaterial shell-based antenna with electric coupling and magnetic coupling has 92% and 82% antenna efficiency with 4.1 FBW. A microstrip DBE-based antenna has a gain of 4.5 dBi with 95% efficiency at the 1.48 GHz frequency. The MPC-based antenna has 6.2 dBi gain with 67.5% antenna efficiency at 2.35 GHz frequency with a high 8.85

FBW. The μ -zero resonance antenna has a 2.9 dBi gain with 86% efficiency with an operating frequency of 7.3 GHz. The SRR spherical wire antenna has 73% efficiency at 403 MHz. The inductively fed vertical SRR antenna has 2.05 dBi and 68.1% efficiency at 2.85 GHz with FBW 20.1%. The CSRR resonator antenna has 2.13-5.04 dBi with 74.5% at 2.82-3.82 GHz with 1.76 FBW. The triple-band antenna (CSRR) has 4.45 dBi and 75.5% efficiency. The RIS meta-surface-loaded antenna has 4.5 dBi gain and 90% efficiency with 6.7 FBW.

The meta-surface-loaded AMC ground-plane antenna has 19 dBi with 80% efficiency at very high frequencies. In this proposed design, CSRR with a rectangular patch antenna with an inset feed provides gain and antenna efficiency with better performance with better lobe results and cross-polarization. The SRRs manifest a capacitive effect at higher frequencies. For feeding the microstrip patch antenna, a novel inset feeding method is used. The simulation is carried out in HFSS Microwave Studio software. The following figure shows the gain pattern of the antenna in the far field. The direction of the maximum gain of the antenna is above the patch.

2. ANTENNA GEOMETRY

Fig.1 delineates geometrical aspects of the Resonator. Presented antenna is implemented with FR4 substrate $\epsilon_r = 4.4$ with dimensions of $30 \times 30 \times 1.6\text{mm}^3$. The Partial ground structure of dimension $11 \times 18 \times 0.018\text{mm}^3$ is implemented to achieve UWB response. A Rectangular CSRR of material Alumina ceramic having the relative permittivity (ϵ_r) of 9.8 instituted upon substrate. This proposed design is a perfect combination of effervescent qualities of dielectric resonator and Patch radiator. A circle shape microstrip patch antenna with stepped microstrip feed produce a dual band frequency response. Inclusion of wide band antenna complements the fields produced by patch. Combination of electric field radiated by MPA and CSRR yields an impedance bandwidth of 7 GHz. Stepped microstrip feed line with slotted partial ground structure amalgamate electric fields produced due to patch and CSRR both. Resultant H-modes are generated from excitation of TM and TE modes and provide a bandwidth ranging from 30-40 GHz. Fig.1(a) shows Top view of dielectric antenna which shows CSRR and patch implementation of structure. Fig. 1(b) shows the side view of Resonator with height of substrate and CSRR. Fig. 1(c) shows the slotted ground structure of the patch resonator antenna.

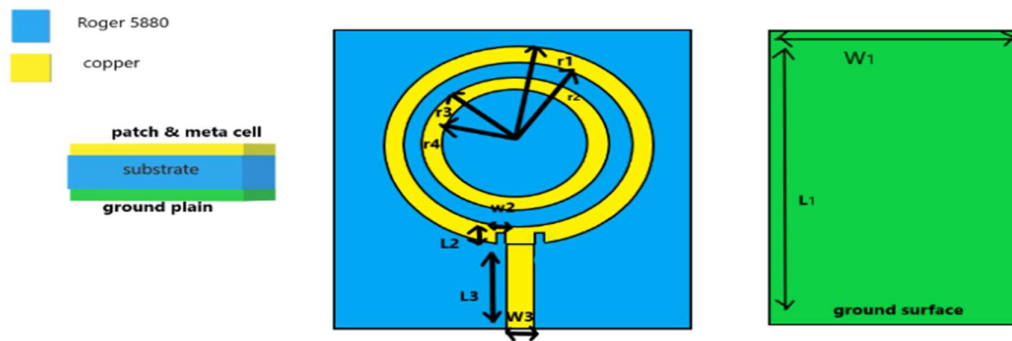

Fig.1 shows geometrical structure of annular patch antenna with top and bottom surface

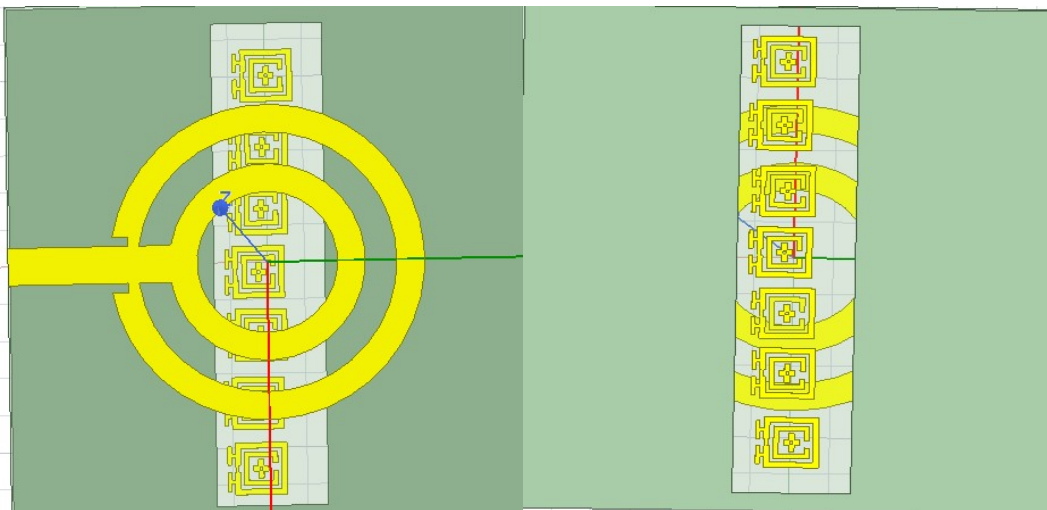

Fig. 2 (a) Peak Outlook (b) Bottom outlook of the antenna

Table 1. Dimensions of proposed antenna structure

Parameter	Dimensions	Parameter	Dimensions
L_1	28	r_1	8.5
W_1	28	r_2	7.75
L_2	1	r_3	5
W_2	1	r_4	6.75
L_3	5	h_1	1.6
W_3	2	h_2	3

(Unit of dimensions is mm)

3. THEORETICAL CONSIDERATION OF DESIGN

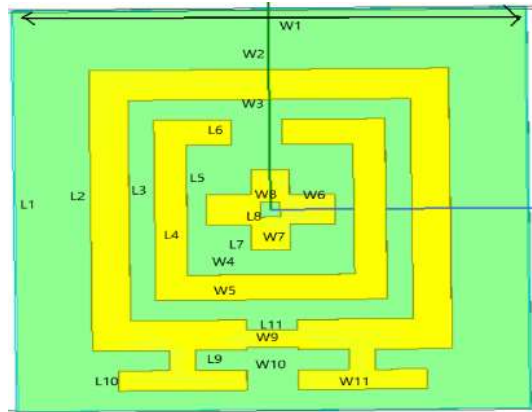

Fig 3 meta cell design

Table 3.1 parameter of meta cell

Parameter	Dimensions	Parameter	Dimensions
L_1	4	W_7	0.15
W_1	4	L_8	0.15
L_2	2.8	L_9	0.2
W_2	2.8	W_8	0.03
L_3	2.2	L_{10}	0.2
W_3	2.8	W_9	0.4
L_4	1.8	W_{10}	1.3
W_4	1.3	L_{10}	0.2
L_5	0.25	W_{11}	1
W_6	0.35	h	0.25
L_7	0.35	t	0.02

In this design, annular ring patch is chosen at first step to implement the hybrid sensor. Ring patch antenna offers dual band properties along with better impedance matching and improved radiation properties. The mathematical analysis of a ring patch can be done with the expression of Resonant frequency

$$f_{rnm} = \frac{X_{nm} \times c}{2\pi\sqrt{\epsilon_r}} \quad (1)$$

Where $c = 3 \times 10^{10}$ is velocity of light in cm/sec
 X_{nm} is the first order Bessel function root and depends on

the mode of the patch.

For TM_{11} mode, the value of $K_{nm} = 0.6773$.

$$X_{nm} = K_{nm} \times a \quad (2)$$

Where n= azimuthal variation

And m shows field variation across the ring width.

The above expressions deliver accurate values when $\frac{r_1-r_2}{r_1+r_2} < 0.35$ and $b = 2 \times a \times c$ conditions are met. 'a' and 'b' both are the inner and outer radii of the patch ring. If the fringing effect is also evaluated then the resonant frequency is given by

$$f_{rnm} = \frac{X_{nm} \times c}{2 \times \pi \times a \times \sqrt{\epsilon_{re}}} \quad (3)$$

$$\epsilon_{re} = \frac{\epsilon_r + 1}{2} + \frac{\epsilon_r - 1}{2} \left[1 + 10 \times \frac{h}{w} \right]^{-\frac{1}{2}} \quad (4)$$

Where ϵ_{re} is the effective dielectric constant and $w = b-a$, is the width of the ring. Dimensions of ring shaped patch are chosen according to (2), Hybrid sensor proposed in this paper is a combination of patch and rectangular dielectric resonator CSRR. Proposed rectangular geometry of CSRR is selected due to the agility provided by designed CSRR. With proper selection of antenna structures dimensions i.e. length (Ld), width (Wd) and height (h2), desired antenna response can be attained. Q-factor of CSRR depends upon aspect ratio of the antenna structure. This CSRR antenna used lowest order mode of Rectangular SSR i.e. TE_{x111} mode. Resonant frequency for this specific mode can be calculated with the following transcendental equation.

$$k_x \tan(k_x Ld/2) = \sqrt{(\epsilon_r - 1)k_0^2 - k_x^2} \quad (5)$$

Where,

$$k_0 = \frac{2\pi}{\lambda_0} = \frac{2\pi f_0}{c}, \quad k_y = \frac{\pi}{Wd} \text{ and } k_x^2 + k_y^2 + k_z^2 = \epsilon_r k_0^2$$

Election of aspect ratio $\frac{Wd}{h2}$ and $\frac{Ld}{h2}$ along with ϵ_r , is important in determining the resonant frequency of RDRA. The expression used for the resolution of above parameter consisting of normalized frequency (F) is given by equation (2):

$$F = \frac{2\pi w f_{0\sqrt{\epsilon_r}}}{c} \quad (6)$$

Unification of microstrip patch and dielectric resonator antenna consequently increases the properties of the overall structure. Easy and simple fabrication technology is a major advantage owned by patch antennas. On the other hand, dielectric resonators offers alleviated gain and efficiency. This research work encompasses around combination of effervescent characteristics of both radiators to attain bandwidth at 9.1 GHz with a higher gain of 5.7 dB and attained average efficiency of 90% throughout the antennas operating range of frequency.

4. EVOLUTION OF THE CSRR PATCH ANTENNA

Evolution stages of the Dielectric antenna is depicted in the Fig. 2. Initial dimensions of the metallic radiator have been calculated by using Eqⁿ3 for a frequency of 10 GHz. RDRA is designed for a frequency of 6.3 GHz by using Eqⁿ 5 and 6. Rest of the structure is modified with the successive stages. As can be seen in Fig. 2(a), annular ring slot is implemented as patch antenna. Subsequently, in Fig. 2(b) Ground plane is reduced to half to radiate like monopole. In Fig. 2(c) twin C-shaped facing each other are incorporated in the partial ground plane to increase capacitive reactance. Fig. 2(d) represents last stage of proposed design. In this design, a wide band DRA is placed upon patch antenna to obtain wide band response.

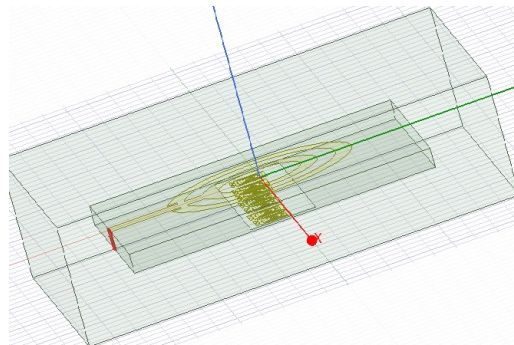

Fig 2. Evolution stages of Antenna

5. RESULTS AND DISCUSSION

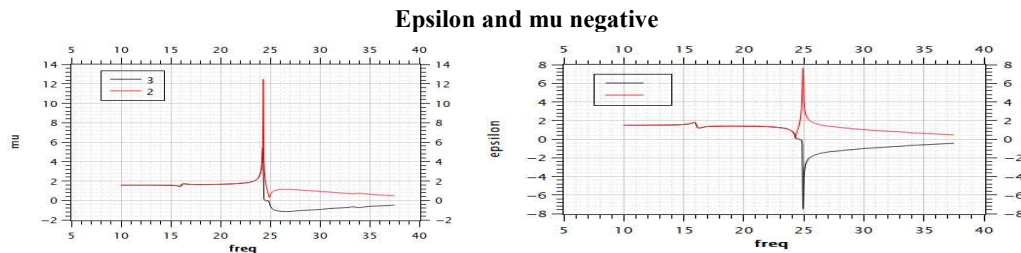

Fig. 4 a) shows negative stage of epsilon and fig.2 b) shows mu negative. this represent both negative material so this

design structure act as a metamaterial which provide antenna better efficiency ,power dissipation, radiation **Radiation pattern**

pattern .Both Epsilon and mu negative give refractive index negative make this structure double negative material.



fig 4 Radiation pattern

6. GRAPHICAL RADIATION PATTERN

Fig. 7 represents the radiation pattern obtained. It is showing pattern that at 40 GHz antenna is acting as Magnetic Monopole Antenna and cross-pol levels are fairly low.at

frequency . The radiation patterns of proposed structure are omnidirectional and depicts that proposed structure radiate like magnetic monopole.

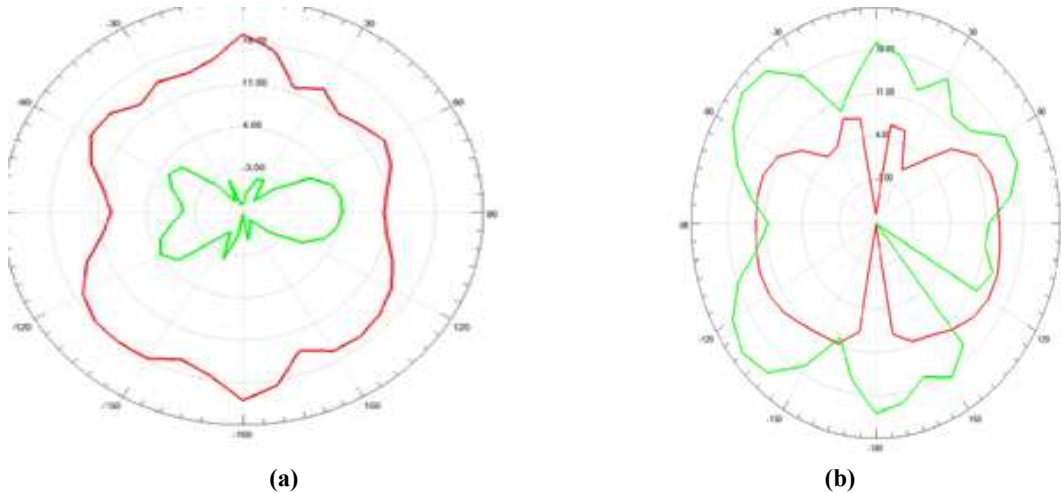

Fig. 5 a) Radiation Pattern for antenna with Co-Polarization & Cross Polarization (Simulated and measured) in ($\phi = 0^\circ$) and ($\phi = 90^\circ$) θ° planes at -40GHz, (b) The Radiation Pattern with Co-Pol and Cross Pol (Simulated and measured) in $\phi = 0^\circ$ and $\phi = 90^\circ$ θ° planes at -40 GHz and (c) Radiation Pattern for antenna with Co-Polarization and Cross Polarization (Simulated and measured) in $\phi = 0^\circ$ and $\phi = 90^\circ$ θ° planes at -40 GHz.

Comparison Table

Table 3 reflects features of different kind of sensors proposed in state of art for ON/OFF body centric applications. This table highlights the key aspects upon

which an antenna can be evaluated. According to the designs proposed till date proposed structure is advantageous in terms of easy fabrication, high gain and efficient antenna for Off /On body communication.

Table 3. Various sensors proposed for WBAN communication

Ref. no.	Shape of DRA	BW (GHz)	Ground Plane (GP)	Antenna size (mm ³)	Conclusion
15	Stair shaped	7–12	Choked GP	20 9 20 9 10.77	Complicated design
16	H-shape DRA	3.47–9.62	Partial GP with slot	30 9 30 9 5.8	Doesn't allocate the tumour size and position

17	Rectangular	22-27	Full GP	30 9 30 9 4.8	Circularly Polarized but intricate structure
18	Cubical shape	4-12	Partially sloted	20 9 15 9 5.64	Dominant mode exists above 10 GHz which may cause ripple effect which leads to inaccuracy
43	RDRA rectangular	5-17	Partially sloted	26 9 18 9 12	Compact design, Single radiator reduces SAR, Low frequency detection of tumour means less ripples
This work	Millimeter wave rectangular CSRR	30-40	Defective ground	30 30 1.6	Compact design, Single radiator reduces SAR, Low frequency detection of tumour means less ripples, high efficiency.

7. CONCLUSION AND FUTURE SCOPE

In this paper, A CSRR metamaterial surface fused with patch antenna to enhance antenna parameters are presented for wide band frequency used for millimetre wave . The 40 GHz millimeter-wave (mmWave) band yields highly granular electromagnetic (EM) scattering data, which significantly improves the precision of tumor localization over lower-frequency microwave systems. shows dielectric contrast Because malignant tissues exhibit a much higher dielectric constant and conductivity than healthy fatty tissues, the contrast allows for highly accurate tumor detection without subjecting patients to ionizing radiation. The primary challenge at 40 GHz is increased tissue attenuation. To maximize penetration and avoid signal loss, the design must be optimized using advanced dielectric superstrates or array configurations. Additionally, Specific Absorption Rate (SAR) constraints must be strictly evaluated to ensure the system remains safe for clinical, non-invasive wearable imaging. Successful implementation will likely rely on integrated multi-antenna arrays coupled with machine learning-based image reconstruction algorithms to enhance diagnostic reliability

REFERENCES

1. Sharma, T., Vashishath , M., Vasisht, P. et al. "A Versatile Ultra-Wideband Radio Sensor for Early Stage Detection of Breast Cancer", MAPAN 36, 891–901 (2021). <https://doi.org/10.1007/s12647-021-00473-x>
2. Vasisht, Parikshit, Mark, Robert and Chatteraj, Neela. "An ultra-wideband rectangular ring dielectric resonator antenna integrated with hybrid shaped patch for wireless applications" Frequenz, vol. 75, no. 9-10, 2021, pp. 399-406. <https://doi.org/10.1515/freq-2020-0218>
3. Sharma, T., Vasisht, P., Vashishath, M. et al. "A novel hybrid ultra-wideband radio sensor for primitive stage detection of breast cancer" , Int. j. inf. tecnol. 13, 983–988 (2021). <https://doi.org/10.1007/s41870-021-00641-x>
4. P. Vasisht, N. Chatteraj, R. Chandra and N. Rajak, "A Novel Compact Ultra-Wide Band MSRDR

for X- and KU-BAND Applications," 2019 URSI Asia-Pacific Radio Science Conference (AP-RASC), 2019, pp. 1-4, doi: 10.23919/URSIAP-RASC.2019.8738749.

5. Amber Khan, Mainuddin, Moin Uddin, and Parikshit Vasisht "A novel UWB compact elliptical-patch antenna for early detection of breast cancer in women with high mammographic density", International Journal of Medical Engineering and Informatics 13:6, 523-533(2021).
6. P. Van Daele, I. Moerman, and P. Demeester, "Wireless body area networks: Status and opportunities," 2014 31th URSI Gen. Assem. Sci. Symp. URSI GASS 2014, pp. 2–5, 2014.
7. I. Al-Barazanchi, H. R. Abdulshaheed, and M. S. Binti Sidek, "A Survey: Issues and challenges of communication technologies in WBAN," Sustain. Eng. Innov., vol. 1, no. 2, pp. 84–97, 2019, doi: 10.37868/sei.v1i2.85.
8. I. Al-Barazanchi, H. R. Abdulshaheed, and M. S. Binti Sidek, "Innovative technologies of wireless sensor network: The applications of WBAN system and environment," Sustain. Eng. Innov., vol. 1, no. 2, pp. 98–105, 2019, doi: 10.37868/sei.v1i2.69.
9. Mark, Z. Wang, E. G. Lim, K. L. Man, J. C. Huang, YiWang, and Leach, "Wireless body area network and its applications," ISOC 2015 - Int. SoC Des. Conf. SoC Internet Everything, pp. 169–170, 2016.
10. A. W. Astrin, H. B. Li, and R. Kohno, "Standardization for Body Area Networks," IEICE Trans. Commun., vol. E92-B, no. 2, pp. 366–372, 2009.
11. E. Jovanov et al., "A WBAN System for Ambulatory Monitoring of Physical Activity and Health Status : Applications and Challenges MS Internet Internet Internet Internet Internet Internet," pp. 3810–3813, 2005.

12. D. Rathee, S. Rangi, S. K. Chakarvarti, and V. R. Singh, "Recent trends in Wireless Body Area Network (WBAN) research and cognition based adaptive WBAN architecture for healthcare," *Health Technol. (Berl.)*, vol. 4, no. 3, pp. 239–244, 2014, doi: 10.1007/s12553-014-0083x.
13. Al-Janabi, I. Al-Shourbaji, M. Shojafar, and S. Shamshirband, "Survey of main challenges (security and privacy) in wireless body area networks for healthcare applications," *Egypt. Informatics J.*, vol. 18, no. 2, pp. 113–122, 2017, doi: 10.1016/j.eij.2016.11.001.
14. Q. Liu, K. G. Mkongwa, and C. Zhang, "Performance issues in wireless body area networks for the healthcare application: a survey and future prospects," *SN Appl. Sci.*, vol. 3, no. 2, pp. 1–19, 2021, doi: 10.1007/s42452-020-04058-2.
15. S. A. Salehi, M. A. Razzaque, I. Tomeo-Reyes, and N. Hussain, "IEEE 802.15.6 standard in wireless body area networks from a healthcare point of view," *Proc. - Asia-Pacific Conf. Commun. APCC 2016*, pp. 523–528, 2016, doi: 10.1109/APCC.2016.7581523.
16. S. M. Ali, C. Sovuthy, M. A. Imran, S. Socheatra, Q. H. Abbasi, and Z. Z. Abidin, "Recent advances of wearable antennas in materials, fabrication methods, designs, and their applications: State-of-the-art," *Micromachines*, vol. 11, no. 10, pp. 2014–2019, 2020, doi: 10.3390/mi11100888.
17. S. Karthikeyan, Y. Venu Gopal, V. Giri Narendra Kumar, and T. Ravi, "Design and Analysis of Wearable Antenna for Wireless Body Area Network," *IOP Conf. Ser. Mater. Sci. Eng.*, vol. 590, no. 1, 2019, doi: 10.1088/1757-899X/590/1/012022.
18. R. Lakshmanan and S. K. Sukumaran, "Flexible Ultra Wide Band Antenna for WBAN Applications," *Procedia Technol.*, vol. 24, pp. 880–887, 2016, doi: 10.1016/j.protcy.2016.05.149.
19. A. R. H. Alhawari, A. H. M. Almagani, A. T. Hindi, H. Alghamdi, and T. Saeidi, "Metamaterial-based wearable flexible elliptical UWB antenna for WBAN and breast imaging applications," *AIP Adv.*, vol. 11, no. 1, 2021, doi: 10.1063/5.0037232.
20. V. S. Ubale and O. S. Lamba, "Flexible Wearable Antennas for Body Area Network," *Int. J. Recent Technol. Eng.*, vol. 8, no. 5, pp. 1561–1565, 2020.
21. A. Sabban, "Active Compact Wearable Body Area Networks for Wireless Communication, Medical and IoT Applications," *Appl. Syst. Innov.*, vol. 1, no. 4, p. 46, 2018.
22. P. B. Samal, P. Jack Soh, and Z. Zakaria, "Compact and Wearable Microstrip-based Textile Antenna with Full Ground Plane Designed for WBAN-UWB 802.15.6 Application," *13th Eur. Conf. Antennas Propagation, EuCAP 2019*, vol. 2019, 2019.
23. Z. H. Jiang, D. E. Brocker, P. E. Sieber, and D. H. Werner, "A compact, low-profile metasurface-enabled antenna for wearable medical body-area network devices," *IEEE Trans. Antennas Propag.*, vol. 62, no. 8, pp. 4021–4030, 2014.
24. Shikder and F. Arifin, "A Novel UWB wearable Icon-Type textile antenna for WBAN applications," *ECCE 2017 - Int. Conf. Electr. Comput. Commun. Eng.*, pp. 886–890, 2017, doi: 10.1109/ECACE.2017.7913028.
25. T. Tuovinen, K. Y. Yazdandoost, and J. Iinatti, "Comparison of the performance of the two different UWB antennas for the use in WBAN on-body communication," *Proc. 6th Eur. Conf. Antennas Propagation, EuCAP 2012*, pp. 2271–3374, 2012, doi: 10.1109/EuCAP.2012.6206090.
26. N. Raghava, A. De, R. Bazaz, P. Arora, A. Samaiyar, and D. Dabas, "High Gain Patch Antenna for WBAN Applications," *SOP Trans. Wirel. Commun.*, vol. 1, no. 2, pp. 34–41, 2014, doi: 10.15764/stowc.2014.02003.
27. W. Wang, X. W. Xuan, P. Pan, Y. J. Hua, H. B. Zhao, and K. Li, "A low-profile dual-band omnidirectional Alford antenna for wearable WBAN applications," *Microw. Opt. Technol. Lett.*, vol. 62, no. 5, pp. 2040–2046, 2020, doi: 10.1002/mop.32270.
28. R. Zaker, C. Ghobadi, and J. Nourinia, "A modified microstrip-fed two-step tapered monopole antenna for UWB and WLAN applications," *Prog. Electromagn. Res.*, vol. 77, pp. 137–148, 2007.
29. A. K. Patel, S. Yadav, A. K. Pandey, and R. Singh, "A wideband rectangular and circular ring-shaped patch antenna with gap coupled meandered parasitic elements for wireless applications," *Int. J. RF Microw. Comput. Eng.*, vol. 30, no. 1, pp. 1–12, 2020.
30. R. B. V. B. Simorangkir, S. M. Abbas, and K. P. Esselle, "A printed UWB antenna with full ground plane for WBAN applications," *2016 Int. Work. Antenna Technol. iWAT 2016*, pp. 127–130, 2016.
31. Y. M. Pan et al., "Design of the millimeter-wave rectangular dielectric resonator antenna using a higher-order mode," *2015 Int. Work. Antenna Technol. iWAT 2015*, vol. 2017, no. 8, pp. 2780–2788, 2017.

32. X. S. Fang, K. W. Leung, and R. S. Chen, "On the wideband notched rectangular dielectric resonator antenna," *Final Progr. B. Abstr. - iWAT 2011 2011 IEEE Int. Work. Antenna Technol. Small Antennas*, Nov. Struct. Innov. Metamaterials, no. 1, pp. 267–270, 2011.
33. R. Al-askalani* (1), H. F. Hammad (1), "Investigation on an UWB Antenna combining a Caped-Monopole and a Dielectric Resonator," *Информационная Безопасность Регионов*, no. 1, pp. 2–5, 2010.
34. U. Illahi et al., "Design of new circularly polarized wearable dielectric resonator antenna for off-body communication in WBAN applications," *IEEE Access*, vol. 7, pp. 150573–150582, 2019.
35. M. M. Tahseen and A. A. Kishk, "Textile-based wideband flexible wearable dielectric resonator antennas for WLAN-band," *2016 17th Int. Symp. Antenna Technol. Appl. Electromagn. ANTEM 2016*, pp. 6–8, 2016.
36. S. H. H. Mashhadi, S. M. Y. Abbas, Z. Wu, and L. Z. Thamae, "Transmission characteristics of wearable broadband textile dielectric resonator antennas in body area network," *Proc. 2012 9th Int. Bhurban Conf. Appl. Sci. Technol. IBCAST 2012*, no. November, pp. 336–339, 2012.
37. A. Iqbal and O. A. Saraereh, "Design and analysis of flexible cylindrical dielectric resonator antenna for body centric WiMAX and WLAN applications," *2016 Loughbrgh. Antennas Propag. Conf. LAPC 2016*, pp. 1–4, 2017.
38. A. R. Chandran, N. Timmons, and J. Morrison, "Compact microstrip line fed dielectric resonator based wearable antenna," *2014 IEEE Conf. Antenna Meas. Appl. CAMA 2014*, pp. 1–4, 2014.
39. M. S. Iqbal and K. P. Esselle, "A compact wideband dielectric resonator antenna for on-body applications," *Conf. Proc. - 2014 IEEE MTT-S Int. Microw. Work. Ser. RF Wirel. Technol. Biomed. Healthc. Appl. IMWS-Bio 2014*, pp. 6–8, 2015.
40. A. M. Faiz, T. Alves, B. Poussot, and J. M. Laheurte, "Diversity antenna combining slot-loop DRA for BAN applications," *Electron. Lett.*, vol. 48, no. 1, pp. 7–8, 2012.
41. A. M. Faiz, N. Gogosh, A. Rehman, M. F. Shafique, B. Poussot, and J. M. Laheurte, "Pattern diversity antenna with high-temperature tolerance for body area networks," *IET Microwaves, Antennas Propag.*, vol. 10, no. 2, pp. 162–167, 2016.
42. D. Guha and C. Kumar, "Microstrip Patch versus Dielectric Resonator Antenna Bearing All Commonly Used Feeds," *IEEE antenna propagation Mag.*, no. February, pp. 45–55, 2016.
43. G. Almpanis, C. Fumeaux, J. Fröhlich, and R. Vahldieck, "A truncated conical dielectric resonator antenna for body-area network applications," *IEEE Antennas Wirel. Propag. Lett.*, vol. 8, pp. 279–282, 2009, doi: 10.1109/LAWP.2008.200521.
44. M. K. Khandelwal, B. K. Kanaujia, and S. Kumar, "Defected ground structure: Fundamentals, analysis, and applications in modern wireless trends," *Int. J. Antennas Propag.*, vol. 2017, 2017.
45. J. Shah and P. Vasisht, "A Novel Metamaterial Inspired Microstrip Patch Antennas for 5G Applications," *2022 International Conference on Smart and Sustainable Technologies in Energy and Power Sectors (SSTEPS)*, Mahendragarh, India, 2022, pp. 233-236, doi: 10.1109/SSTEPS57475.2022.00065.
46. J. Shah and P. Vasisht, "Metamaterial based Ring Shaped MSA Antenna for 5G & Wireless Applications," *2022 International Conference on Smart and Sustainable Technologies in Energy and Power Sectors (SSTEPS)*, Mahendragarh, India, 2022, pp. 241-244, doi: 10.1109/SSTEPS57475.2022.00067.
47. Vasisht, Parikshit & Parashar, Taruna & Shah Jaimini & Ranjan Sudhakar(2022) "RDRA Sensor for Primal Detection of Breast Cancer Cells in Women" *IEEE conference* 316-319. doi: 10.1109/SSTEPS57475.2022.00084.
48. Shah, J. and Vasisht, P. (2025) 'A novel compact planer millimeter wave sensor for breast cancer detection' *Advances in Consumer Research* 2(6), pp. 870-877.
49. J. shah and P. Vasisht, "A Terahertz Operating Novel Antenna Absorber For Breast Cancer Detection", *IJASIS*, pp. 1588–1604, Dec. 2025, doi: 10.29284/wn7zcb73.

